

# PRACTICAL ELECTRONIC DESIGN

*for Experimenters*

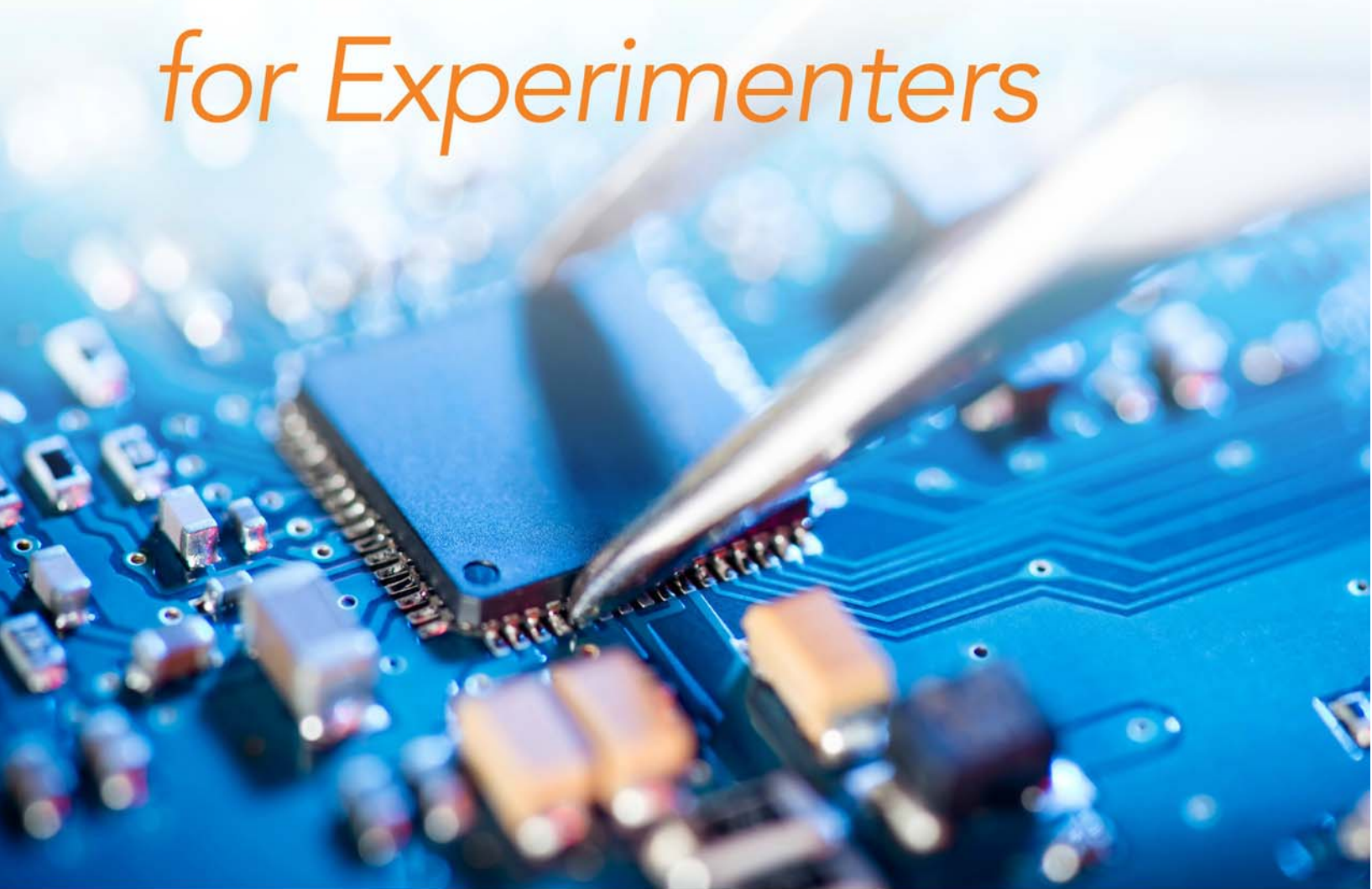

**Mc  
Graw  
Hill**



**LOUIS FRENZEL**



# **Practical Electronic Design for Experimenters**

*This page intentionally left blank*

# Practical Electronic Design for Experimenters

Louis E. Frenzel, Jr.



New York Chicago San Francisco Athens London Madrid  
Mexico City Milan New Delhi Singapore Sydney Toronto

Copyright © 2020 by McGraw-Hill Education. All rights reserved. Except as permitted under the United States Copyright Act of 1976, no part of this publication may be reproduced or distributed in any form or by any means, or stored in a database or retrieval system, without the prior written permission of the publisher.

ISBN: 978-1-26-045616-5

MHID: 1-26-045616-1

The material in this eBook also appears in the print version of this title: ISBN: 978-1-26-045615-8, MHID: 1-26-045615-3.

eBook conversion by codeMantra

Version 1.0

All trademarks are trademarks of their respective owners. Rather than put a trademark symbol after every occurrence of a trademarked name, we use names in an editorial fashion only, and to the benefit of the trademark owner, with no intention of infringement of the trademark. Where such designations appear in this book, they have been printed with initial caps.

McGraw-Hill Education eBooks are available at special quantity discounts to use as premiums and sales promotions or for use in corporate training programs. To contact a representative, please visit the Contact Us page at [www.mhprofessional.com](http://www.mhprofessional.com).

Information contained in this work has been obtained by McGraw-Hill Education from sources believed to be reliable. However, neither McGraw-Hill Education nor its authors guarantee the accuracy or completeness of any information published herein, and neither McGraw-Hill Education nor its authors shall be responsible for any errors, omissions, or damages arising out of use of this information. This work is published with the understanding that McGraw-Hill Education and its authors are supplying information but are not attempting to render engineering or other professional services. If such services are required, the assistance of an appropriate professional should be sought.

## TERMS OF USE

This is a copyrighted work and McGraw-Hill Education and its licensors reserve all rights in and to the work. Use of this work is subject to these terms. Except as permitted under the Copyright Act of 1976 and the right to store and retrieve one copy of the work, you may not decompile, disassemble, reverse engineer, reproduce, modify, create derivative works based upon, transmit, distribute, disseminate, sell, publish or sublicense the work or any part of it without McGraw-Hill Education's prior consent. You may use the work for your own noncommercial and personal use; any other use of the work is strictly prohibited. Your right to use the work may be terminated if you fail to comply with these terms.

THE WORK IS PROVIDED "AS IS." MCGRAW-HILL EDUCATION AND ITS LICENSORS MAKE NO GUARANTEES OR WARRANTIES AS TO THE ACCURACY, ADEQUACY OR COMPLETENESS OF OR RESULTS TO BE OBTAINED FROM USING THE WORK, INCLUDING ANY INFORMATION THAT CAN BE ACCESSED THROUGH THE WORK VIA HYPERLINK OR OTHERWISE, AND EXPRESSLY DISCLAIM ANY WARRANTY, EXPRESS OR IMPLIED, INCLUDING BUT NOT LIMITED TO IMPLIED WARRANTIES OF MERCHANTABILITY OR FITNESS FOR A PARTICULAR PURPOSE. McGraw-Hill Education and its licensors do not warrant or guarantee that the functions contained in the work will meet your requirements or that its operation will be uninterrupted or error free. Neither McGraw-Hill Education nor its licensors shall be liable to you or anyone else for any inaccuracy, error or omission, regardless of cause, in the work or for any damages resulting therefrom. McGraw-Hill Education has no responsibility for the content of any information accessed through the work. Under no circumstances shall McGraw-Hill Education and/or its licensors be liable for any indirect, incidental, special, punitive, consequential or similar damages that result from the use of or inability to use the work, even if any of them has been advised of the possibility of such damages. This limitation of liability shall apply to any claim or cause whatsoever whether such claim or cause arises in contract, tort or otherwise.

# Contents

---

Introduction .....	xi
<b>1 Introduction to Electronic Design .....</b>	<b>1</b>
Defining Design .....	1
Design Perspective .....	1
Get a Design Notebook .....	2
Get a Calculator .....	2
A Standard Design Approach .....	3
Design Doctrine Dozen .....	9
Types of Design .....	10
Prerequisites for Design .....	11
A Design Example .....	11
An Alternative Beginning .....	14
<b>2 Design Resources .....</b>	<b>15</b>
Books .....	15
Sources of Catalogs, Components, and Equipment .....	15
Magazines .....	16
Data Sheets .....	16
Applications Notes .....	17
Useful Web Sites .....	17
Educational Sources .....	18
Back to Basics .....	18
Searches .....	18
<b>3 Simulation and Prototyping .....</b>	<b>19</b>
Circuit Simulation .....	19
Recommendation .....	21
Breadboarding .....	21
Dead Bug Method .....	25
Working with Surface-Mount Components .....	25
Components .....	25
One Good Prototyping Practice .....	26
A Workbench .....	26
Summarizing .....	26

A Word About Tools .....	26
Your Projects .....	27
<b>4 Testing and Measuring .....</b>	<b>29</b>
Multimeters .....	29
How to Use a Multimeter .....	29
Power Supply .....	30
Oscilloscopes .....	32
Function Generators .....	33
Virtual Instruments .....	33
Circuits for Testing .....	34
Power Supply .....	35
Signal Sources .....	35
Making <i>L</i> and <i>C</i> Measurements .....	36
<b>5 Common Circuit Design Techniques .....</b>	<b>39</b>
Drawing Circuits .....	39
Series-Dropping Resistor .....	39
Voltage Dividers .....	41
Special Sensor Resistors .....	43
Potentiometers .....	44
Error and Accuracy .....	45
Variable Voltage Dividers .....	45
Transistor Switches .....	45
Design Example 5.1 .....	48
Design Example 5.2 .....	49
Design Project 5.1 .....	49
Design Project 5.2 .....	50
Design Project 5.3 .....	50
Design Project 5.4 .....	50
Design Project 5.5 .....	50
<b>6 Power Supply Design .....</b>	<b>51</b>
Power Supply Choices and Specifications .....	51
The Make vs. Buy Decision .....	52
Common Voltages .....	52
Designing a Battery Supply .....	52
Ampere-Hour Ratings .....	53
Battery Supply Design Procedure .....	54
Battery Supply Enhancements .....	55
Specifying a Linear Supply .....	56
Linear Supply Design Procedure .....	58
Linear Supply Design Example .....	60
Switch-Mode Power Supplies (SMPS) .....	64
Pulse-Width Modulation .....	66



Design Project 6.1 .....	68
Design Project 6.2 .....	68
Design Project 6.3 .....	68
Design Project 6.4 .....	68
<b>7 Amplifier Design.....</b>	<b>69</b>
Amplifier Types .....	69
Specifying Amplifiers.....	69
Understanding the Specifications .....	70
A Microphone Amplifier.....	73
Designing with Op Amps .....	73
Primary Op Amp Application Circuits.....	76
Differential Amplifier .....	80
Error Source Compensation .....	81
Comparators .....	82
Power Amplifiers .....	83
Design Projects .....	85
Design Project 7.1 .....	85
Design Project 7.2 .....	86
Design Project 7.3 .....	86
Design Project 7.4 .....	86
<b>8 Signal Source Design .....</b>	<b>87</b>
Signal Source Specifications .....	87
Sine Wave Oscillators.....	87
Clock Oscillators .....	92
Multivibrators .....	93
Frequency Synthesizers .....	97
Design Project 8.1 .....	100
Design Project 8.2 .....	100
Design Project 8.3 .....	100
Design Project 8.4 .....	101
Design Project 8.5 .....	101
Design Project 8.6 .....	101
<b>9 Filter Design.....</b>	<b>103</b>
Types of Filters .....	103
Filter Specifications .....	105
Filter Design Guidelines .....	106
Filter Response Options .....	106
RC Filter Design .....	107
Bandpass LC Filters .....	109
Band Reject Filters .....	110
RC Active Filters .....	112
Low-Pass Filter .....	113

LC Filter Design . . . . .	113
Switched Capacitive Filters . . . . .	114
DSP Filters . . . . .	115
Design Project 9.1 . . . . .	115
Design Project 9.2 . . . . .	116
Design Project 9.3 . . . . .	116
Design Project 9.4 . . . . .	116
<b>10 Electromechanical Design . . . . .</b>	<b>117</b>
Switches . . . . .	117
Relays . . . . .	118
Solenoids . . . . .	121
Motors . . . . .	122
Motor Control . . . . .	122
Servo Motors . . . . .	124
Design Project 10.1 . . . . .	125
Design Project 10.2 . . . . .	125
Design Project 10.3 . . . . .	126
<b>11 Digital Design . . . . .</b>	<b>127</b>
Three Design Approaches . . . . .	127
Preliminary Design Decisions . . . . .	129
Combinational Logic Circuits . . . . .	129
DeMorgan's Theorem . . . . .	131
Functional ICs . . . . .	132
Practical Digital Design Procedures . . . . .	133
Design Example . . . . .	134
Designing with a Programmable ROM . . . . .	135
TTL vs. CMOS . . . . .	136
Sequential Logic Circuits . . . . .	137
Flip Flops . . . . .	137
Counters and Registers . . . . .	138
State Machine Design . . . . .	140
Design Example . . . . .	141
Data Conversion . . . . .	143
Data Conversion ICs . . . . .	144
Design Project 11.1 . . . . .	145
Design Project 11.2 . . . . .	145
Design Project 11.3 . . . . .	146
Design Project 11.4 . . . . .	147
Design Project 11.5 . . . . .	147
Design Project 11.6 . . . . .	147
Design Project 11.7 . . . . .	147
Design Project 11.8 . . . . .	147
Design Project 11.9 . . . . .	148

<b>12</b>	<b>Programmable Logic Devices (PLDs)</b> .....	<b>149</b>
	Programmable Logic Types .....	149
	Programming PLDs .....	149
	Complex Programmable Logic Devices .....	151
	FPGA Dominance .....	151
	Application Decisions .....	152
	An Introduction to VHDL and Verilog .....	153
	Development Boards .....	153
	Coding the Digital Circuit with an HDL .....	154
	FPGA Learning Resources .....	155
	Development Board Sources .....	156
	Summary .....	156
<b>13</b>	<b>Designing with Microcontrollers</b> .....	<b>157</b>
	Embedded Controller Design Process .....	157
	Choosing an MCU and the Software .....	159
	More About Selecting an MCU or Processor .....	161
	Software and Programming .....	164
	Programming Language Examples .....	165
	Some Takeaways .....	167
	Learning to Love BASIC .....	167
	The Case for Assembly Language .....	168
	Microdesign Considerations .....	170
	Microinterfacing .....	171
	A Plan for Learning Micros .....	174
	Committing to a Microfuture .....	174
	Design Project 13.1 .....	175
	Design Project 13.2 .....	175
	Design Project 13.3 .....	175
<b>14</b>	<b>Component Selection</b> .....	<b>177</b>
	Resistors .....	177
	E-24 Resistor Values—5 percent .....	178
	E-96 Resistor Values—1 percent .....	178
	Special Resistors .....	179
	Potentiometers .....	180
	Capacitors .....	181
	Inductors .....	182
	Semiconductor Selection .....	183
<b>15</b>	<b>Troubleshooting and Debugging</b> .....	<b>187</b>
	Mitigating the Need for Hardware Troubleshooting .....	187
	Test Equipment .....	188
	Prototype Troubleshooting .....	188
	Electrical Problems .....	189

Troubleshooting Procedures .....	190
Component Failure Likelihood .....	190
A Troubleshooting Example .....	191
Continuity Testing .....	192
General Troubleshooting Suggestions.....	193
Software Debugging .....	194
Troubleshooting Practice.....	194
<b>A Recommended Reference Books .....</b>	<b>197</b>
<b>B Solutions to Design Projects .....</b>	<b>199</b>
<b>C Transistor Amplifier Design.....</b>	<b>217</b>
<b>D How to Use Karnaugh Maps .....</b>	<b>223</b>
Index .....	229

# Introduction

---

This book is for you experimenters and makers who want to design your own electronic circuits and equipment. There are not too many books like this. Most books tell you how electronic devices work and provide some projects to learn from. But now you have in your hands a book that is actually going to show you how to design your own electronic circuits and equipment. It is written in a way so that any of you who have a background in electronic fundamentals can create a circuit or device to do something you want to do. You don't have to be an engineer to design things.

With the knowledge and procedures in this book, you can create products for resale, implement scientific projects that need special equipment, or produce circuits for your own DIY (do-it-yourself) idea. The book relies upon the availability of popular integrated circuits and the many finished modules and subassemblies. Using existing products and legacy circuits eliminates most of the difficult circuit design. In many cases, you can piece together existing circuits and modules to make a device with minimal electronic design. However, some basic circuit design is usually necessary and hopefully, this book will help with that.

The design approach in this book focuses on making a working device using standard parts and circuits. The recommendations in each chapter suggest that you use chips and circuits that have been used before. Why reinvent the

wheel? The result is lesser design time and greater success at lower cost. Your design may not always be “leading-edge” but it will do the job.

## You Are the Target Audience

When writing this book, I had the following people in mind:

- Hobbyists, experimenters, DIYers, and makers who want to create their own equipment.
- New engineers—graduates who are well versed in math, physics, and electronic fundamentals but have not yet learned to apply that knowledge to creating products.
- Technicians who are knowledgeable in electronics but have not designed.
- Scientists like physicists, chemists, geologists, and other users of electronic equipment who often need custom noncommercial equipment but can learn to design their own.
- Students who can supplement their theoretical studies with practical design knowledge. Students in an introductory college design course or taking a design capstone course or culminating design project course where the theory is applied to a specific circuit or device.

It is likely that you are part of one those groups.

## Book Rationale

Where does one generally go to learn electronic design? At colleges or universities offering a BSEE degree, of course. These institutions teach all the science, math, theory, components, and circuits. Some courses actually teach related design. Much of the design taught in college is how to design integrated circuits using special software created for that purpose. Yet, many colleges and universities rarely address modern practical product design. There is a need to learn how to translate theory into practice by creating useful end products. This book addresses that void. It is unique and serves a need. Not everyone can go to college, but that does not mean you cannot learn design. In fact, in the real world BSEE graduates go out to jobs and that is where they really learn the design process. On the job training (OJT) is where you get actual design experience. Now you can get a taste of that with this book.

## Functions of This Book

- Illustrates a practical, almost “cook book” approach that you can use to create new devices or design equipment to solve a unique problem not met by available existing products.
- Shows you how to create your own devices from scratch.
- Introduces basic systems design processes to define the product.
- Shows how standard off the shelf (OTS) products can be used to create the desired end product.
- Emphasizes that large segment of electronic design today is actually at the product level rather than the component and circuit level.
- Illustrates that you do not necessarily need a college degree to design some types of electronic products.

## Prerequisites

The book assumes that you have some minimal level of knowledge or experience in electronics. While formal college-level electronic education is preferred, any training or instruction in the fundamentals from the military service, company classes, or by personal self-learning will probably be adequate. At a minimum you should be familiar with these topics:

- Ohm’s law
- Kirchhoff’s laws
- Resistors and capacitors in series and parallel
- How transistors operate (BJT and MOSFET)
- Basic digital logic

This book reviews some of this material and uses the “teaching moment” that explains selected necessary basic theory along with the design processes.

## Math

You should know up front that this book does use some mathematics. After all, design is the process of calculating electronic values to implement a specific circuit. It is a necessary part of design. That may be bad news for some of you who hate math. Get over it. The good news is that most of the math is pretty simple. For example, many calculations are just the process of plugging numerical values into a given formula and grinding out the math. Other math is basically just algebra. You may have to rearrange a formula to solve for a different variable but it rarely gets more complex than that. Get yourself a good scientific calculator, use the calculator that is in your smartphone, or tap the calculator in the Windows operating system. It’s not that hard.

## Book Features

- A first design book for the inexperienced maker and experimenter.
- Chapters covering the most common types of circuits and equipment.
- Provides the knowledge to immediately create new devices.
- Describes well-known circuits and short cuts that always work.
- Related theory, basic principles, or background covered briefly as needed.
- Provides design projects that will help you apply and test your design ability.
- Recommends standard available parts.
- Includes design examples.
- Provides a collection of popular circuits that always work, which you can use as building blocks for new designs.
- Math level: Mainly algebra, some elementary trigonometry, and basic logarithms. No calculus.

## Design Projects

Included at the end of each chapter are several Design Projects. These are provided to help you apply the design procedures. The project may be just a demonstration or a major design assignment. Be sure to do these as they provide the practice you need to become competent in design. Simulate, build, and test your design. Typical solutions are given in Appendix B to further illustrate proper techniques as well as the kinds of decisions that you may need to make. Be sure to read all of the Design Projects and their solutions in Appendix B. These solutions give you a significant amount of additional design tips, approaches, and processes.

## What This Book Does Not Cover

- Leading-edge circuit design. Once you learn and practice the basic design procedures given in this book, you can then move on to more sophisticated and complex designs.
- Integrated circuit design. This is usually done with expensive electronic design automation (EDA) software. It also does not cover the current semiconductor processes and chip-making techniques.
- Mechanical design and packaging. This includes printed circuit board (PCB) design and manufacturing. Electronic packaging is a whole different field of expertise where you need to know about chemicals, metals, plastics, and other related technologies.
- PCB design. Another mechanical function that is mostly handled by software these days. A world of its own.
- Programming. Software and programming are mentioned in the chapter on microcontrollers, but no programming languages or techniques are taught. Hopefully you know some programming but if not, don't worry. The amount of software coverage included here is minimal.

## Book Content

This is basically a hardware book. Its approach encourages hands-on experimentation by building things. The book is also a bit “retro.” The book includes many older circuits and techniques. Why? Mainly they are still available, affordable, proven to work, and easy to design with. Your goal is to design some useful device so why try to devise a complex high-tech circuitry device when cheap simple circuits and processes work?

The main focus is analog or linear circuits but an extensive digital chapter is included. Introductory chapters on PLDs/FPGAs and microcontroller design are provided as a starting point for your future work with these subjects.

## What's in It for You?

You will be spending time and money working with this book. Why should you do that? Here are a few benefits to consider.

- You get to satisfy your interest in electronics by working with hands-on projects.
- You will develop your natural human desire to create things and solve problems.
- You will be able to design and build practical and useful electronic devices.
- You will learn more electronics. Design is a great teacher. It makes the theory come alive in the circuit or device you are designing. And you will never find a better way to really understand electronics until you have to design actual circuits and equipment.
- You may even improve your knowledge and skills to the extent that they could be useful in your job if you work in the electronics industry.
- Have fun with your hobby.

## Three Pieces of Advice

### Failure Is an Option

First, do not be afraid to fail. Experiment. If in doubt, try it out. If that does not work, try something else. Failure is a common occurrence in design. Examples are a circuit that does not work at all and one that works but does not meet the specifications. Each failure is just a learning process. Be patient. You will eventually figure out something that works. Failure is just part of the overall learning experience that design provides.

## Enjoy the Process

I can tell you right now that there is probably nothing more satisfying than to design something, build it and see it works successfully. There is true delight in that accomplishment. Have the fun and feel the reward of achievement.

## Invest in Yourself

Finally, let me say this to you experimenters and makers. Plan to invest in some test equipment, prototyping hardware, software, and components. Without good test and measurement capability, you cannot actually evaluate what you are designing. Full prototype construction is recommended despite the availability of excellent simulation software. You never really know for sure how a product performs until you actually build and test one.

## How to Use This Book

Start by rereading this Introduction again. Definitely read Chapter 1 first to get the big picture about electronic design. Then go on and read Chapters 2 through 4 and do what they say. Specifically, put together a basic book library (Appendix A), so you will have some ready references if you need them. Next, set up your workbench. That includes acquiring the necessary tools, test equipment, and breadboarding equipment. Track down a circuit simulator software like Multisim and get it installed on your PC.

As a first project, I suggest you next go to Chapter 5. It has multiple circuits that you will use again and again in other designs. Complete the Design Projects given. Simulate them and/or breadboard them and run the physical tests. Get some experience in breadboarding and testing. You will come to appreciate how time consuming all this is.



Now you can go on to the chapters on specific designs. If you do not have a good laboratory power supply, you may want to go to Chapter 6 next and build your own power supply.

You are on your own after that. You can go to any other chapter as it fits your needs.

Again, I urge you to build and test the Design Projects given in each chapter. It

will give you practice in breadboarding and/or using the simulation software. Some possible design solutions are given in Appendix B. Finally, as you go through the book, you will discover a product or circuit that interests you. Start the design and follow through.

Now, go design something.

*This page intentionally left blank*

# Introduction to Electronic Design

---

Product design is the process of creating an electronic circuit, device, or piece of equipment. It may be a new commercial product for sale to generate new revenue and profit. Or it could be a highly specialized device needed as part of a scientific research effort. Then again it may be the brainchild of a hobbyist or experimenter for entertainment or learning purposes. The design process varies widely from engineer to engineer or from company to company. Yet despite the differences, the processes have common elements or essential steps. This chapter attempts to identify these common and necessary steps and to generate a cookbook design method that you can use to create a product.

## Defining Design

The formal definition of design is to conceive and plan from your own mind some idea, process, or object—to create something using one’s intelligence and experience by defining look, function, and operation. The result is often original and may be patentable. While that definition applies to this book, there is another definition that is more applicable. That is, design is developing an electronic product, circuit, or device for some useful purpose. That design can include existing circuits, components, and techniques. Design is combining standard, well-known circuits, parts, and methods to solve a problem or produce some useful new device. Using proven circuits, parts, and methods will improve the chances of success, reduce costs, and save design time.

## Design Perspective

Designing electronic circuits has evolved over the years from designing circuits with discrete components to designing in two other major ways. The most sophisticated and original circuit design today is done by engineers in the semiconductor companies. These engineers use computer-aided design software to facilitate both the circuit design and the manufacturing of semiconductors. This is where the real innovative designs come from. You still get to design with individual transistors and capacitors, but at the software level. This is probably the highest-level design because it requires significant theoretical knowledge, experience, and natural creativity. Engineers who do this probably have advanced degrees as well as plenty of experience.

The second form of electronic design is what some call the connect-the-pins approach. What that means is that the engineer designs products by selecting appropriate integrated circuits (ICs) and then connecting their pins to produce the final product. Some say this is not a very creative process because it can be done without a whole lot of theory and experience. This is probably the most common form of electronic design where engineers are developing products, not chips. If you know how the chips work, you can probably do this type of design. The most challenging parts of the design are printed circuit board (PCB) design and writing the software or firmware for the ubiquitous microcontroller that is usually part of most designs.

This book covers design much like the connect-the-pins approach. It offers an almost cookbook-like method for conceiving of a product and making it. With literally thousands of different types of ICs out there, you need to be creative to put them together in one of the almost infinite number of ways possible to accomplish your design goal. Best of all, you really do not have to be a graduate engineer to do it. But you do need to meet the prerequisites discussed elsewhere.

Two key points to consider are:

- Know your chips. Get familiar with the available ICs, dig out the details of those of interest, and get relevant data sheets, app notes, etc. Keep track of new chip introductions by monitoring the semiconductor company Web sites and keeping up with industry magazines and Web sites.
- Become software literate. Learn to code in a popular language, and become proficient in writing programs for micros. The future is firmware.

The remainder of this book will take you down that path.

## Get a Design Notebook

Before listing the design steps, you should acquire a notebook that you will use to document your design. It will contain statements of purpose, goals, features, benefits, specifications, test results, identified problems, and other defining data. The notebook will also be used to contain your calculations, draw your block diagrams and schematics, and record test and measurement data. The design notebook can be anything you are comfortable with. A standard-size spiral bound school notebook is a good choice. They are available in most big box stores like Walmart and Target, office supply

stores, grocery stores, and pharmacies. Special engineering notebooks containing grid paper are great and useful but also expensive and not really necessary.

Do not skip this first step. You must keep notes and record details so that you know what works and what does not. You want to maintain all facts and figures, schematics, calculations, test results, and debugging notes in one place so you can reference them later if needed. And be sure to get into the habit of putting the date on each page.

Many companies absolutely require engineers to maintain a design notebook to document the progress and retain the experience and knowledge they acquire during the design. It also documents the activities in case the outcome is a patentable circuit, process, or product. Writing everything down will take some getting used to, and it may aggravate you at first. Eventually you will discover how useful the notebook is since we all tend to forget. You must document everything. This is especially true in writing software code. Chances are your design will include a microcontroller for which you will write some programs. Documenting this process is critical. If you or someone else needs to revise or fix the software, you will appreciate any explanations or other details you find there. Documenting can be aggravating, but get over it—before long you will grow to appreciate the record-keeping process.

## Get a Calculator

When you design, you will be making calculations. Most of the calculations are simple formulas to solve or at worst, some basic algebra. You may need to rearrange a formula to solve for a different variable, for example. For these calculations you need a scientific calculator. The calculator should include scientific notation, trigonometry

functions, logarithms, and other engineering calculation functions. Individual calculators are available, but you do not need anything fancy. Programmable calculators are nice but are not needed for this book. You can also use the calculator built into your Windows operating system or your smartphone. I still use an old Texas Instruments calculator I have had for decades. Use whatever works best for you.

## A Standard Design Approach

The design approach introduced here is covered in these basic stages:

- Definition
- Detail design
- Simulation (optional)
- Prototype
- Testing
- Packaging
- Use

### Definition Stage

Figure 1.1 shows a flowchart of the key steps in the definition stage of the design.

1. Name the product. Give it a name that tells others what it is or does.
2. Describe the product by writing out a short paragraph. State why it is needed, by whom, and what it is supposed to do. Be as detailed as possible, but keep it short if you can. This description is mainly for you, but it could be used by your supervisor, a marketing person, or a customer.
3. List the main features of the product. What will it do? What are some important characteristics that allow it to solve a problem or perform a function not available elsewhere? What do the sales and marketing people want? If this is a product for sale,

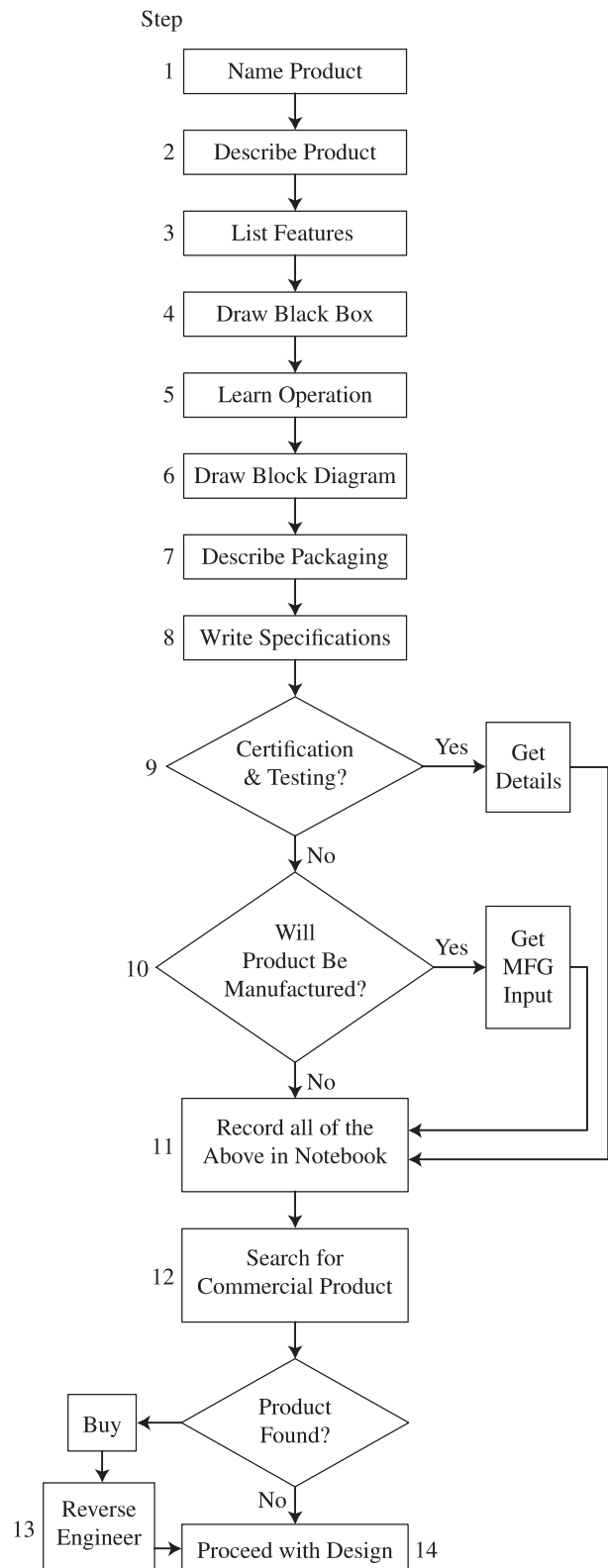
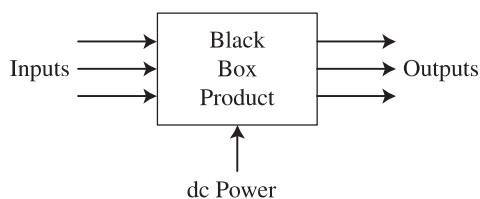

**Figure 1.1**

A flowchart that summarizes the main steps in designing an electronic circuit or product.

what features should be included to make the product attractive to buyers? Who are the competitors, if any? Identify their products and do a comparison. If necessary, negotiate the features with the sales and marketing team. Then finalize the features list.

4. Treating the product as a “black box,” identify the inputs and the outputs. See Fig. 1.2. An electronic circuit or product can be viewed as a box of signal processing and manipulation that responds to one or more inputs and then generates one or more outputs. Describe each signal in as much detail as possible. Also identify where the inputs come from and where the outputs go. Be sure to include the ac and/or dc power requirements. Again, be as detailed as you can at this early stage.
5. Learn how the device or circuit works. This is the time for detailed research. You can’t design something unless you know how it works. You must learn the concepts, theory, and operational details of something before you can design it. Use any available textbooks to identify circuits and configurations. At this point you should also do an internet search to determine some details about your project. Search on the product name you assigned, and use alternative descriptions to gather as much information as you can. Search on circuit names, component part numbers, or whatever other detail you may have or need. Look for block diagrams, schematic



**Figure 1.2** The “black box” concept that applies to most electronic circuits or products.

diagrams, how-it-works descriptions, and the like. If competitive products are available, acquire them if the budget allows. If you want to design something but don’t know where to start, it is probably because you do not know how it functions. As an example, at one time I wanted to design a metal detector. How hard could it be? But I was stumped. I did not even know what circuits it contained or how they work together to locate metal objects. So go back and reread this step.

6. Draw a block diagram of the device. Knowing the theory of operation and the inputs and outputs, you can probably generate a first attempt to see what circuits and modules or other subassemblies you may need. State the purpose of each stage. Do the best you can at this point, and keep in mind it will change as you learn more. For you real beginners, Table 1.1 summarizes all the most common circuits engineers use.
7. Describe the most desirable physical packaging. What will the end product look like mechanically? Will it use a printed circuit board (PCB)? This book does not delve into the physical packaging of a design, but you still need to determine it.
8. Write out a set of specifications. Knowing the inputs, outputs, and power requirements, you should be able to list key specifications. Some of these are frequency range, input and output voltage levels, specific signal shapes and conditions, estimated power supply voltages, data rate, interface requirements, and current limits. You also need to add any special environmental conditions, such as temperature range, humidity, vibration/shock, and electromagnetic interference (EMI) considerations. Add physical specifications like desired size, weight, and

**Table 1.1** The most commonly used electronic circuit building blocks and what each does

Circuit	Function	Available IC or module? Other
Amplifier	Takes a small input voltage or power and boosts it up by some gain factor to a larger output.	Yes, usually. All types available.
Analog-to-digital converter (ADC)	Samples an analog signal and produces a digital output.	Yes, many.
Attenuator	A circuit that reduces the amplitude of voltage or power by some loss factor usually expressed in decibels (dB).	There may be. A resistive voltage divider or network is more common.
Buffer	A circuit, usually an amplifier, that isolates one circuit from another to prevent or minimize loading that affects output voltage, power, or frequency.	Maybe. Could be analog or digital.
Clock	An oscillator that generates accurate rectangular pulses used for timing and operating an MCU or other digital circuits.	Yes.
Comparator	Takes two input signals, one usually a fixed reference voltage and the other a varying amplitude signal, and provides an output signal that indicates which input is equal to, less than, or more than the other.	Yes.
Counter	A circuit that keeps track of the number of binary input pulses that are applied to its input. The output is in binary format.	Yes, multiple.
Driver	A circuit that operates some other device like a motor, relay, LED, or servo.	Yes, usually. Could be just a transistor or an IC.
Decoder	A digital circuit that looks at multiple lines of binary signals and detects one or more separate output conditions, each recognizing a unique code.	Yes.
Detector	A circuit that indicates the presence of a signal. Another name for a demodulator.	Maybe.
Digital-to-analog converter (DAC)	A circuit that translates its binary input into the analog equivalent.	Yes, many.
Divider	A digital circuit that produces an output that is lower in frequency than the input. Also, an analog circuit that splits an input into two or more equal outputs.	Some. An often-designed circuit to fit the application. A digital counter makes a good frequency divider.
Filter	A circuit that allows some frequencies to pass and others to be stopped or at least greatly attenuated.	Yes. Some filters can be designed with discrete components to fit the application.
Follower	A high input impedance–low output impedance circuit that provides some isolation between amplifier stages as well as some power gain. See Buffer.	No. Usually a circuit designed for the application.
Frequency synthesizer	A signal source like an oscillator that generates a sine wave or rectangular wave.	Yes. Multiple kinds. Two major versions like phased-locked loop (PLL) and direct digital synthesis (DDS).

*(Continued)*

**Table 1.1** The most commonly used electronic circuit building blocks and what each does (*Continued*)

Circuit	Function	Available IC or module? Other
Function generator	A signal source that usually generates sine, square, and triangular waves for testing.	Yes.
Gate	Basically, just a switch that blocks a signal until another enabling signal is applied. May also perform some digital (boolean) logic function.	Yes, both analog and digital types.
MCU	Microcontroller unit. An embedded microcontroller or single chip computer that is the basis of most other products today.	Yes, many. Something for every application.
Memory	A storage circuit for binary words or data.	Yes, Many kinds.
Mixer	Two types, linear and RF. Linear mixers combine multiple analog inputs into a composite signal, as in an audio mixer that adds multiple musical instruments and two or more microphones. The RF mixer serves as an up converter or down converter for translating signals to a higher or lower frequency, as in radio transmitters or receivers.	A few.
Modulator	A circuit that varies the amplitude, frequency, or phase of a higher frequency carrier signal for the purpose of transmitting information by wireless.	Yes, not many.
Multiplexer	A circuit with two or more inputs and a single output and a means of selecting any one of these to appear at the output.	Yes, both digital and analog versions are available.
Oscillator	A circuit that generates a signal, analog or digital, at a specific frequency or over some variable frequency range.	Yes, multiple types. RC, LC, crystal.
Rectifier	A circuit that converts ac into pulsating dc that is usually smoothed into a continuous voltage by a capacitor.	No. Usually made with discrete diodes.
Regulator	A circuit that maintains a fixed output voltage despite changes in other operational factors like input voltage or output load.	Yes, many types for all occasions.
Register	A circuit made up of flip flops that can store a binary value or manipulate it.	Yes, multiple types.
Voltage-controlled oscillator (VCO)	A signal source whose output frequency can be varied by applying a dc control voltage.	A few.
Voltage divider	A circuit made primarily with resistors that produces an output that is lower than the input.	A circuit that must usually be designed. Capacitor and inductor dividers can be made but are not common.

power consumption. Also consider ease of use, maintenance, and potential repair. The end product should be simple to operate with minimal training or instruction.

9. Consider required testing and certification. If you are designing a product for resale,

you may need to meet some required set of standards mandated by law. Examples are ac-powered devices that may have to be tested by the Underwriters Laboratories (UL) or the Federal Communications Commission (FCC).



10. Will the product be manufactured? If this is a one-off product, skip this step. If the product will be made in volume, be sure to involve the manufacturing people in evaluating the design and getting their input regarding steps to make the device from initial PCB construction through final testing and packaging.
11. Record all of this information in your notebook.
12. Next, you should look to see if what you defined is already a product available for sale. Maybe you won't have to design it if you can purchase a ready-made version. Do an extensive internet search. Use different product names or descriptions to be sure you will locate something similar. If you find something similar, acquire as much information as you can, and compare its features and specs to your definition. Buy the product if you can afford it.
13. Reverse engineer the product. Take it apart, being careful not to damage anything. Do the following:
  - a. Take photos along the way.
  - b. Identify all of the major subassemblies and larger components, and document any wiring between these sections.
  - c. Identify the power source like the ac line or batteries and the related power supply.
  - d. If PCBs are involved, remove them, but record any interconnections by way of connectors or wiring.
  - e. Develop the schematic diagram from the PC board. Identify how the copper traces on the PCB connect the various components. Your initial schematic diagram will be messy and crude, but you can redraw it later in a more useful way.
  - f. Identify the individual components. Read the resistor color codes, read capacitor values, any read numbers or part numbers on the ICs, and transistors. Record all this on the schematic diagram.
  - g. Redraw the schematic diagram and part numbers and values. NOTE: In many products, the labels on the ICs will be omitted to prevent someone from identifying the part and copying the circuit. If that is the case, maybe later you can deduce what it is.
  - h. Given your copied design, consider whether you could duplicate this item. If you can, you can adopt the design for your own version. If you do not believe that you can duplicate it, just reassemble the product and use it. Then move on to another project.
14. If no commercial product turns up to buy, press on with the design.

## Detail Design Stage

This is where you fill in the boxes in your block diagram with specific circuits, modules, or other units. Think of the various circuits available and how you can use them as building blocks. From your searches you should have identified the circuits or ICs you want to use. Identify specific circuits where you can. Search for specific ICs that do what you need. You should be able to determine that you need an amplifier, a filter, a digital counter, LCD display, or whatever. You may do some rough partitioning at this point as you identify different parts of the design. For example, you may have an analog signal or linear segment, a digital segment, and a power supply segment. Then, for the first time, try to draw a schematic diagram of the design.

Next you will choose components to match your circuit specifications. You will be selecting ICs, diodes, transistors, capacitors, resistors, potentiometers, transformers, and a mix of other parts. You should have catalogs on

hand from the major distributors if you can get them. Otherwise, go online to the major distributor sites to select your parts. You can also do additional internet searches to find what you need and to get additional information from data sheets, application notes, and other sources.

## Simulation Stage

You can also call this the verification stage. This is an optional process where you validate that your circuits will work. You can use circuit simulation software to build the circuits and product on the computer before making an actual prototype. More details are given in Chap. 3. Simulation is a good learning experience, but it does take time to learn the software and the simulation process. You could go directly to a hardware prototype for testing. But I recommend you give simulation a try.

## Prototype Stage

Now you start building your prototype. Build each circuit one at a time and make each work alone. Guidelines for prototyping and breadboarding are given in Chap. 3. Once you define each circuit's function, you can begin connecting circuits together to form the final product.

## Testing Stage

Testing is the final stage. This is covered in Chap. 4. You will test your device to see that it implements all of the desired features. You will also test to see that it meets the specifications you assigned earlier. You can expect to do some troubleshooting at this time to fix problems, fine-tune the design to meet specifications, or correct errors. Chapter 15 covers troubleshooting. Occasionally you will, as they say, "have to go back to the drawing board."

## Packaging Stage

At this point your product is finished and it works. And by now you should have thought about how the product should be packaged. What is its housing? How are the circuits wired? No doubt a PCB is required. Packaging is a mechanical design process beyond the scope of this book. Yet it is important, especially if you plan to market the device as a commercial product.

## Use Stage

Manufacture, sell, or use the product.

One final thing. As indicated earlier, this product design process does not include considerations for high-volume manufacturing. The design process for manufacturing is similar, but serious consideration is given to cost of manufacturing, ease and speed of manufacturing, special testing or alignment procedures, and parts availability.

Design examples using the process described here are given in the design chapters to come. Here is a summary.

- Chapter 5 Common Circuit Design Techniques. Basic circuits and concepts you will use in most designs.
- Chapter 6 Power Supply Design. Battery and ac to dc supplies.
- Chapter 7 Amplifier Design. Mostly op amps, but some discrete designs.
- Chapter 8 Signal Source Design. Oscillators, clocks, synthesizers.
- Chapter 9 Filter Design. RC, LC, active, and modules.
- Chapter 10 Electromechanical Design. Switches, relays, motors, servos.
- Chapter 11 Digital Design. Discrete IC logic.
- Chapter 12 Programmable Logic Devices.
- Chapter 13 Designing with Microcontrollers. Interfacing and I/O and programming.

## Design Doctrine Dozen

The rules for design in this book are based on the premise that you are trying to design something that will work reliably, have a reasonable cost, and take less time to create. Your goal should be to create a product that works, solves a problem, or fills a need. Here are the guidelines for design as recommended in this book.

1. Keep it simple, stupid (KISS). Simple designs are always best. They are less complex, less expensive, and take less time to create. And they are generally more reliable.
2. Do not reinvent the wheel. Use existing circuits and designs. Borrow liberally from magazine articles, books, manufacturer's data sheets, application notes, and online sources. Why spend extra time experimenting with new approaches when there is probably already a design you can access and use? Seek out and maintain a library of standard circuits that work. I keep a file folder for different types of useful circuits (amplifiers, oscillators, logic circuits, etc.) When I come across a magazine article, internet printout, or data sheet, I file it for future use. Put together these existing designs in different combinations as needed. Modify these circuits as needed to create your design. There should be no embarrassment in using the designs of others if you can. Most basic electronic functions have been discovered and implemented. These are mostly in the public domain, and you are free to use them. Take advantage. It is OK to be creative and design some things from scratch, but just remember it takes more time, and you may need to redesign it multiple times to get what you want. While not everything has been invented yet, it is difficult to devise a design that is totally original. Most common operations have already been developed many times in a variety of forms.
3. Old designs are just fine. Old circuits and components are not bad. If it works and solves the problem, use it.
4. Cheaper is usually better.
5. It does not have to be leading edge. You will not be designing your own ICs. Use existing chips when you can.
6. Use manufacturers' reference designs. Many semiconductor manufacturers have already designed what you may need. A reference design is a predesigned device using the manufacturer's ICs. It is usually a prewired PCB with connectors and in some cases software—everything you need to get started without having to design it yourself. These evaluation boards are recommended because they save time and money.
7. Use manufacturers' design tools. Design tools are software that semiconductor manufacturers develop to help engineers design selected circuits. The software that is typically available online simply walks you through the design process and leads to a design for you. Of course, the tools will typically lead you to the company's ICs or other devices to implement it.
8. Use free or low-cost design software from the internet. Circuit simulation software is available from multiple sources. Feel free to use it to develop your design. However, always build and test a real prototype to be sure it works.
9. Use existing well-known ICs, transistors, and other components. There are multiple sources, and the cost is low. For commercial designs, some companies require that there be one or more secondary sources for ICs, transistors, and other parts. Then if one manufacturer discontinues the part, you will

still be able to get it elsewhere. Chapter 14 gives you some recommendations.

10. A microcontroller design is not always the best approach. Most products today are based upon a central embedded controller. These microcontroller units (MCUs), or micros as I refer to them here, are flexible and cheap, but they require software and programming in addition to the electronic interface design. Sometimes a simple hardware design is the fastest and cheapest solution.
11. Focus your budget on good test equipment and prototyping equipment. You cannot really design without testing and measuring equipment. So, plan to set aside a budget for a good multimeter, oscilloscope, and breadboarding gear.
12. Learn and have fun. Experiment. Screw up. Fail. Learn what works and what does not. Then eventually achieve success.

### **WARNING!**

In designing commercial products, some circuits and methods may really be new and patentable. These circuits or methods become valuable intellectual property (IP) to your employer. Such IP may give some company competitive benefits. Or the company could license the design to generate royalty income. This is especially true of IC designs, but it could apply to some other arrangement. Just be sure to document everything in your notebook in case it comes up.

## **Types of Design**

When designing any electronic circuit or product, you will discover that there are lots of ways to do it. My own view of this is that there are three basic design approaches. Here is a summary of each.

### **Textbook Design**

You could also call this the traditional approach. This is the process of designing a circuit or

product by using standard textbook theory and procedures. There are multiple textbooks to help you do this. The procedures are well known and generally proven. They are taught in college. This approach does not use cookbook recipes but offers the theory with examples, then tests you with end-of-chapter problems. The theory is given, but its interpretation and its implementation are left to you. This book generally uses this approach, but it is supplemented with a bit of experience that yields some step-by-step procedures that save time.

### **Empirical Design**

This approach is design by experimentation. You can also call it the cut-and-try method. You essentially start with something you know, then observe the result. If it is not what your goal is, you experiment. You change or add something, observe the outcome, then change again if the end result does not turn out as you want. You go back and learn some more. You keep on learning, testing, experimenting until you get what you want. It sounds crazy, but it works, especially for those with some experience in the subject. After a while you get to know what works and what does not.

### **Intuitive Design**

This is an approach that is based upon years of acquiring knowledge and experience that in turn give you the intuition to create something new. Your design is based upon your intuition without supporting facts. You go with what you know and believe to be true. Or as they say, you go with your gut.

After years of design experience, I have come to believe that a person inherits some of each approach. You start with the textbook approach, learn more as you experiment with the empirical approach, then finally with sufficient knowledge and experience you go with the intuitive approach.

## Prerequisites for Design

This book will give you a basic process for designing. Along the way, it will also review some of the related electronic fundamentals. This book assumes that you already have a general working knowledge of electronics. Ideally you will have had some formal training or education in electronics or relevant experience. Self-taught is OK, too. At a bare minimum, you should know Ohm's law, how transistors work, some basic digital logic, and which end of a soldering iron gets hot.

To help in this regard, you should acquire some books to use for reference if you need to learn some fundamentals or refresh your knowledge. Appendix A is a list of books I recommend. They cover the fundamentals and provide some additional information on design. Build a library of such books. Some are expensive, but remember you can always find used ones on Amazon or other internet sources. You can never have too much information. If you are designing, you must seek out and acquire as much reference material from multiple sources as you can.

## A Design Example

Here is how you might approach a project using the steps described earlier. This is the process I went through on one project.

### The Definition Stage

1. Metal detector.
2. The metal detector should detect buried metal items to a depth of 10 to 20 cm. It will be used to see what treasures are buried in beaches, back yards, and other patches of ground that might provide potential targets.
3. Main features:
  - a. Identify metal at a depth of 10 to 20 cm.
  - b. Portable.
  - c. Lightweight.
  - d. Battery operated.
  - e. Speaker and/or headphone output.
  - f. Relatively easy to build as a first or early hobby project.
4. The black box concept is relatively simple:
  - a. Input, search coil
  - b. Output, speaker or headphones
5. Searching on the topic of metal detectors produces a ton of information. A detailed search using the terms "How do metal detectors work" and "metal detector circuits" produces a considerable amount of detail. Summary:
  - a. There are four basic types of metal detectors: very low frequency (VLF), pulse, heterodyne, and variable tone.
  - b. The first two (VLF and pulse) require some sophisticated circuitry that may be difficult to understand without extensive research and experience. These two types are also the most expensive. The third type uses a heterodyne method that mixes two signals together to get a difference frequency in the audio range. The simplest detector is the variable tone type.
  - c. One type uses an audio oscillator whose tone changes if metal is near the search coil. The second type uses two oscillators, one at a fixed frequency and another whose frequency can be varied by the presence of nearby metal. The two oscillator frequencies are mixed together. The result is a frequency in the audio range that represents the difference between the two oscillator frequencies. Tone changes signal the presence of metal.
6. I was able to draw a crude block diagram of both methods. See Fig. 1.3.

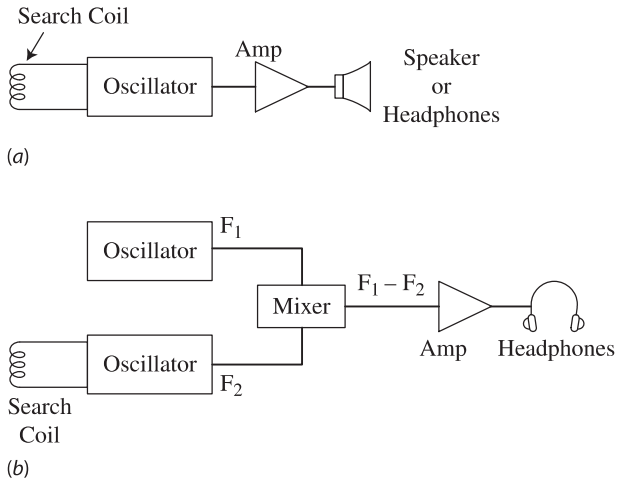

**Figure 1.3** First black box diagrams for the project. The upper drawing shows the single oscillator approach (a) and the lower drawing showing the two oscillator design (b).

7. Physical packaging is not critical since you are making the product for your own use. It should have an enclosure to hold a battery and the circuitry, a search coil that can reach the ground, and a place to plug in some headphones.
8. No specifications other than those features described in step 3 were written since they are not applicable to noncommercial devices.
9. No testing or certification is required for personal products.
10. The product will not be manufactured in quantity.
11. I did write down all the details in my notebook.
12. A search for a commercial product did occur. There are many. From low-cost hobby models for less than \$100 to military-grade units for finding mines costing thousands of dollars. No commercial product was purchased.
13. No reverse engineering took place.
14. The design process will go on.

## The Design Stage

The design stage started with expanding and improving upon the block diagram produced earlier. The heterodyne type of detector was chosen. Two oscillators are used, so a search for oscillators started. Search data obtained earlier showed several oscillator possibilities. The difficult part was deciding on a frequency of operation. Apparently a wide range is used. I decided upon something in the 50 to 200 kHz range.

One of the oscillators uses a large coil of wire as the search head but also as the inductance in a tuned circuit for one of the oscillators. I searched for as much detail as possible here and more or less summarized the current form and size of circuits I discovered. A popular inductance value as a target is 10 mH. I suspect some experimentation will be needed here.

Next I needed a mixer that would produce the difference frequency between the two oscillators. The designers of this circuit use an XOR gate. I'm not sure how that works, but it apparently does.

I also needed an audio amplifier to operate the headphones.

A second method of detection that I call variable tone uses an oscillator whose frequency is changed by being close to a metal object. It is a simple circuit, and it seems cheap and easy to try. I suspect that the heterodyne method is much better.

Figure 1.4 shows the simple circuit. A 555 timer IC is used as an oscillator with a tuned RLC circuit setting the frequency. This frequency is in the audio range so you can hear it. With the values shown in the figure, the frequency computes to 1073 Hz.

The big design obstacle is the inductance that not only sets the frequency but also serves as the search coil. The desired inductance is 10 mH. The search coil is many turns of copper wire whose diameter is in the 4- to 10-inch-diameter range. Approximately 140 to 150 turns of wire